

# **User's Manual**

## **EPIA-NR**

Version 1.12  
November 6, 2008

## **Copyright**

Copyright © 2005-2008 VIA Technologies Incorporated. All rights reserved.

No part of this document may be reproduced, transmitted, transcribed, stored in a retrieval system, or translated into any language, in any form or by any means, electronic, mechanical, magnetic, optical, chemical, manual or otherwise without the prior written permission of VIA Technologies, Incorporated.

## **Trademarks**

All trademarks are the property of their respective holders. PS/2 is a registered trademark of IBM Corporation. Award BIOS is a registered trademark of Phoenix Technologies Ltd.

## **Disclaimer**

No license is granted, implied or otherwise, under any patent or patent rights of VIA Technologies. VIA Technologies makes no warranties, implied or otherwise, in regard to this document and to the products described in this document. The information provided in this document is believed to be accurate and reliable as of the publication date of this document. However, VIA Technologies assumes no responsibility for the use or misuse of the information in this document and for any patent infringements that may arise from the use of this document. The information and product specifications within this document are subject to change at any time, without notice and without obligation to notify any person of such change.

## **FCC-B Radio Frequency Interference Statement**

This equipment has been tested and found to comply with the limits for a class B digital device, pursuant to part 15 of the FCC rules. These limits are designed to provide reasonable protection against harmful interference when the equipment is operated in a commercial environment. This equipment generates, uses and can radiate radio frequency energy and, if not installed and used in accordance with the instruction manual, may cause harmful interference to radio communications. Operation of this equipment in a residential area is likely to cause harmful interference, in which case the user will be required to correct the interference at his personal expense.

### **Notice 1**

The changes or modifications not expressly approved by the party responsible for compliance could void the user's authority to operate the equipment.

### **Notice 2**

Shielded interface cables and A.C. power cord, if any, must be used in order to comply with the emission limits.



Tested To Comply  
With FCC Standards  
FOR HOME OR OFFICE USE

## Safety Instructions

1. Always read the safety instructions carefully.
2. Keep this User's Manual for future reference.
3. Keep this equipment away from humidity.
4. Lay this equipment on a reliable flat surface before setting it up.
5. The openings on the enclosure are for air convection hence protects the equipment from overheating. **DO NOT COVER THE OPENINGS.**
6. Make sure the voltage of the power source and adjust properly 110/220V before connecting the equipment to the power inlet.
7. Place the power cord in such a way that people cannot step on it. Do not place anything over the power cord.
8. Always unplug the power cord before inserting any add-on card or module.
9. All cautions and warnings on the equipment should be noted.
10. Never pour any liquid into the opening. Liquid can cause damage or electrical shock.
11. If any of the following situations arises, get the equipment checked by a service personnel:
  - The power cord or plug is damaged
  - Liquid has penetrated into the equipment
  - The equipment has been exposed to moisture
  - The equipment has not work well or you cannot get it work according to User's Manual.
  - The equipment has dropped and damaged
  - If the equipment has obvious sign of breakage
12. **DO NOT LEAVE THIS EQUIPMENT IN AN ENVIRONMENT UNCONDITIONED, OR IN A STORAGE TEMPERATURE ABOVE 60°C (140°F). THE EQUIPMENT MAY BE DAMAGED.**



### Caution:

Only use the appropriate battery specified for this product.  
Do not reuse, recharge, or reheat an old battery.  
Do not attempt to force open the battery.  
Do not discard used batteries with regular trash.  
Discard used batteries according to local regulations.



## **Box CONTENTS**

---

- One VIA Nano-ITX Mainboard
- One ATA-133/100 IDE Ribbon Cable
- Nano-ITX Power Cable
- USB Cable
- One Driver and Utilities CD
- Two Screws for VGA Connector



## TABLE OF CONTENTS

---

Box Contents .....	v
Table of Contents.....	vii
Chapter 1 .....	1
Specifications .....	1
Mainboard Specifications .....	2
Mainboard Layout .....	4
Back Panel Layout.....	5
Chapter 2 .....	7
Installation .....	7
CPU .....	8
Memory Module Installation.....	10
Connecting the Power Supply .....	11
Back Panel Ports .....	12
Connectors.....	13
Jumpers .....	20
Slots .....	22
Chapter 3 .....	23
BIOS Setup .....	23
Entering Setup.....	24
Control Keys.....	25
Navigating the BIOS Menus.....	26
Getting Help .....	27
Main Menu .....	28
Standard CMOS Features.....	30
IDE Drives.....	31
Advanced BIOS Features .....	32
CPU Feature .....	36
Hard Disk Boot Priority .....	38
Advanced Chipset Features.....	39
AGP & P2P Bridge Control .....	41
CPU & PCI Bus Control .....	43
Integrated Peripherals.....	44
VIA OnChip PCI Device .....	45
USB Device Setting .....	46
Power Management Setup.....	48
Wakeup Event Detect.....	50
PNP/PCI Configurations.....	52

PC Health Status.....	54
Frequency / Voltage Control .....	55
DRAM Clock/Drive Control .....	56
Load Fail-Safe Defaults .....	58
Load Optimized Defaults .....	59
Set Supervisor / User Password .....	60
Save & Exit Setup .....	62
Exit Without Saving.....	63
Chapter 4 .....	65
Driver Installation .....	65
Driver Utilities.....	66
CD Content.....	68

# CHAPTER 1

## Specifications

The ultra-compact and highly integrated VIA EPIA-NR uses the Nano-ITX mainboard form-factor developed by VIA Technologies, Inc. as part of the company's open industry-wide total connectivity initiative. The mainboard enables the creation of an exciting new generation of small, ergonomic, innovative and affordable embedded systems. Through a high level of integration, the Nano-ITX occupies only 50% of the size of Mini-ATX mainboard form factor. The mainboard comes with an embedded VIA Processor, boasting of ultra-low power consumption, cool and quiet operation.

## **MAINBOARD SPECIFICATIONS**

---

### **CPU**

- VIA C7® 1.0GHz NanoBGA2 processor

### **Chipset**

- VIA CX700 Advanced All-in-One chipset

### **Graphics**

- Integrated UniChrome™ Pro II 3D/2D AGP graphics with MPEG-2 video decoding acceleration

### **Audio**

- VIA VT1708A High Definition Audio Codec

### **Memory**

- 1 x DDR2 533 SODIMM slot (up to 1 GB)

### **Expansion Slot**

- 1 x Mini-PCI slot

### **IDE**

- 1 x UltraDMA 133/100 connector (2.54mm, 40-pin)

### **Serial ATA**

- 2 x SATA connectors

### **LAN**

- VIA VT6107 10/100 Mbps Fast Ethernet Controller or VIA VT6122 Gigabit Ethernet Controller (Optional)

**Back Panel I/O Ports**

- 1 x RJ45 LAN port
- 1 x VGA port

**Onboard I/O Connectors**

- 1 x USB pin connector for 6 additional USB 2.0 ports
- 1 x LPC pin connector
- 1 x SMBus pin connector
- 2 x Serial port pin connectors (COM 1 5V/12V selectable)
- 2 x LVDS Power pin connectors
- 1 x LVDS Panel pin connector to support 2 single-channel LVDS panels or 1 dual-channel panel (optional)
- 1 x CF (Compact Flash) Type I connector (shared with IDE, master / slave select by jumpers)
- 1 x PS2 Mouse/Keyboard pin connector
- 1 x Audio pin connector for Line-out, Line-in, MIC-in, and S/PDIF out
- 1 x Front Panel pin connector
- 2 x Fan connectors for CPU and system fans
- 1 x Nano-ITX power connector

**BIOS**

- Award BIOS with LPC 4/8Mbit flash memory capacity

**Form Factor**

- Nano-ITX (8-layer)
- 12cm X 12cm

**Note:**

1. Due to the hardware limitation, DDR2 SDRAM chips organized as 128Mb x 8 bank cannot be supported by EPIA products with CN700 and CX700M2 chipsets.
2. When connecting two single-channel panels, the two panels must have the same timing specification and resolution.

# MAINBOARD LAYOUT

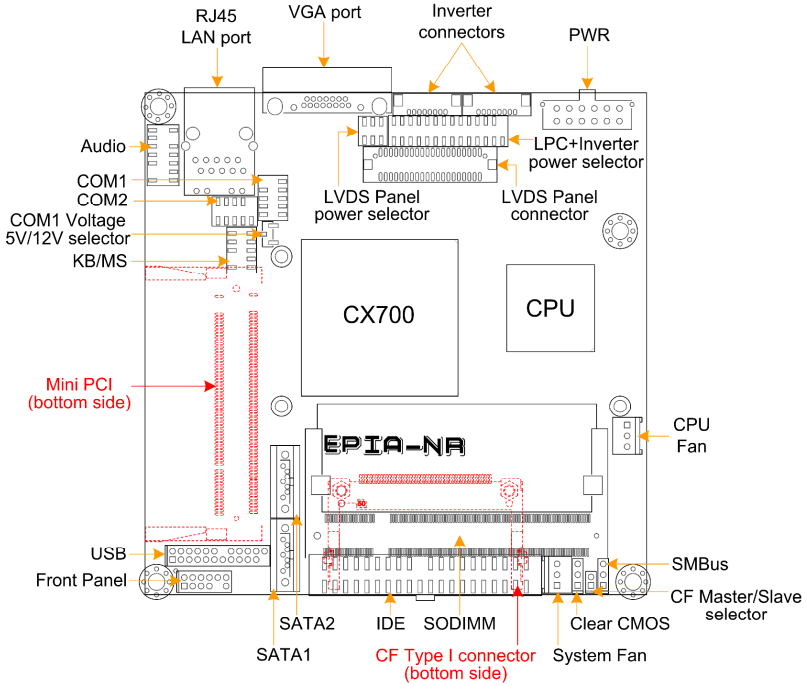

## BACK PANEL LAYOUT

---

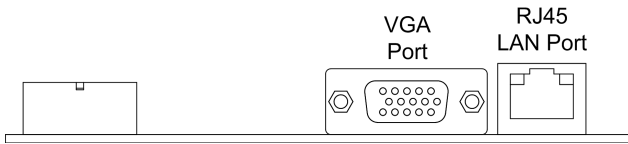



# CHAPTER 2

## Installation

This chapter provides you with information about hardware installation procedures. It is recommended to use a grounded wrist strap before handling computer components. Electrostatic discharge (ESD) can damage some components.

## CPU

The VIA EPIA-NR Nano-ITX mainboard includes an embedded VIA C7 V4 Bus Processor. The VIA C7 V4 Bus Processor requires only a heat sink to provide sufficient cooling.

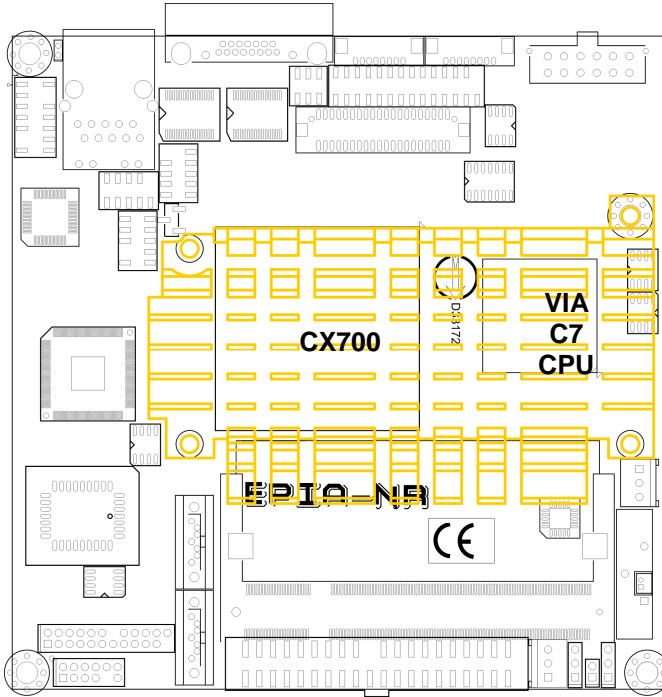

## CPU Fan and System Fan: CPUFAN and SYSFAN

The CPUFAN (CPU fan) and SYSFAN (system fan) run on +12V and maintain system cooling. When connecting the wire to the connectors, always be aware that the red wire is the Positive and should be connected to the +12V. The black wire is Ground and should always be connected to GND.

### CPUFAN

Pin	Signal
1	NC
2	+12V
3	GND

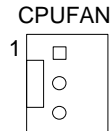

### SYSFAN

Pin	Signal
1	NC
2	+12V
3	GND

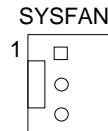

## MEMORY MODULE INSTALLATION

---

### Memory Slot: DDR2\_SODIMM

The VIA EPIA-NX Nano-ITX mainboard provides one SODIMM slot for DDR2 533 SDRAM memory modules and supports memory sizes up to 1GB.

Insert the SODIMM module at a 45 degree angle.

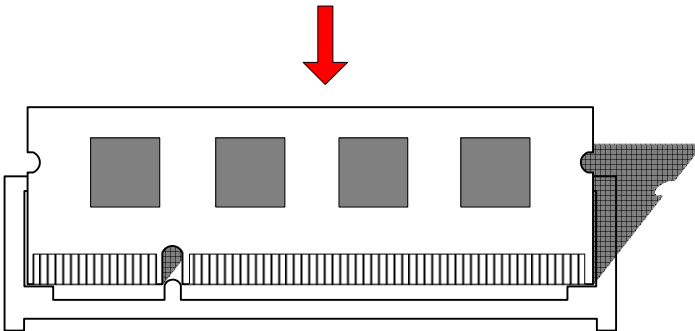

Push the SODIMM module back towards the board until the clips lock the module in place.

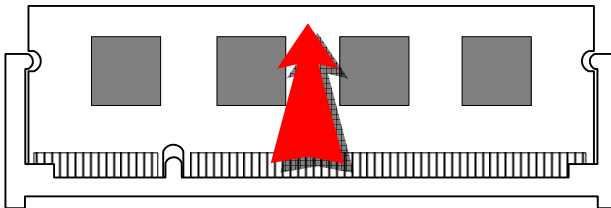

### Available DDR2 SDRAM Configurations

Refer to the table below for available DDR2 SDRAM configurations on the mainboard.

Slot	Module Size	Total
SODIMM	64MB, 128MB, 256MB, 512MB, 1GB	64MB-1GB
Maximum supported system memory		64MB-1GB

---

## CONNECTING THE POWER SUPPLY

---

The VIA EPIA-NX Nano-ITX mainboard supports a Nano-ITX power supply for the power system. Before inserting the power supply connector, always make sure that all components are installed correctly to ensure that no damage will be caused.

### Nano-ITX 12-Pin Power Connector

To connect the power supply, make sure the power plug is inserted in the proper orientation and the pins are aligned. Then push down the plug firmly into the connector.

Pin	Signal
1	+3.3V
2	+3.3V
3	+3.3V
4	+5VSUS
5	GND
6	+12V
7	-PSON
8	+5V
9	GND
10	+5V
11	GND
12	PWRGD

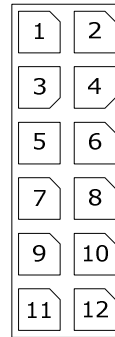

## BACK PANEL PORTS

---

The back panel has the following ports:

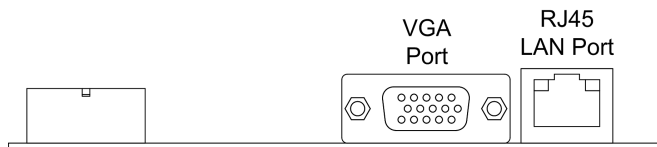

### VGA Port

The 15-pin female VGA connector can be used to connect to any analog VGA monitor.

### RJ45 LAN Port

The mainboard provides a standard RJ45 port for enabling connections to networks.

## CONNECTORS

### IDE Connector: IDE

The mainboard has an Ultra DMA 133/100 controller. You can connect up to two IDE devices in any combination.

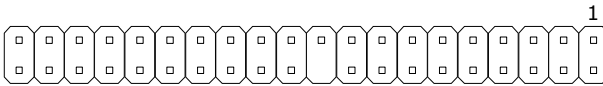

If two drives are connected to a single cable, the jumper on the second drive must be set to slave mode. Refer to the drive documentation supplied by the vendor for the jumper settings.

Pin	Signal	Pin	Signal
1	#IDE_RST	2	GND
3	PD_7	4	PD_8
5	PD_6	6	PD_9
7	PD_5	8	PD_10
9	PD_4	10	PD_11
11	PD_3	12	PD_12
13	PD_2	14	PD_13
15	PD_1	16	PD_14
17	PD_0	18	PD_15
19	GND	20	NC
21	#PD_REQ	22	GND
23	#PD_IOW	24	GND
25	#PD_IOR	26	GND
27	#PD_RDY	28	PRIMARY
29	#PD_ACK	30	GND
31	PD_IRQ15	32	NC
33	PD_A1	34	IDE_DMADET
35	PD_A0	36	PD_A2
37	#PD_CS1	38	#PD_CS3
39	#HD_LED1	40	GND

**Serial ATA Connectors: SATA1 and SATA2**

These next generation connectors support the right angle Serial ATA cables for primary internal storage devices. The current Serial ATA interface allows up to 150MB/s data transfer rate, faster than the standard parallel ATA with 133 MB/s (Ultra DMA).

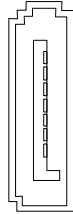

**USB Pin Connector: USB**

The mainboard provides 1 USB pin connector that allows up to 6 USB 2.0 ports to be added. This port can be used to connect high-speed USB interface peripherals such as USB HDD, digital cameras, MP3 players, printers, modem and the like.

Pin	Signal
1	VUSB0
3	USBD_T0+
5	USBD_T0-
7	GND
9	USBD_T1-
11	USBD_T1+
13	GND
15	VUSB4
17	USBD_T4-
19	USBD_T4+
21	GND
23	KEY

Pin	Signal
2	VUSB2
4	USBD_T2+
6	USBD_T2-
8	GND
10	USBD_T3-
12	USBD_T3+
14	KEY
16	VUSB4
18	USBD_T5-
20	USBD_T5+
22	GND
24	GND

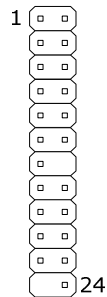

## Case Connector: FPNL

The FPNL pin header allows you to connect the power switch, reset switch, power LED, HDD LED and the case speaker.

Pin	Signal	Pin	Signal
1	+PWR_LED	2	+HD_LED
3	+PWR_LED	4	-HD_LED
5	-PWR_LED	6	PW_BN
7	SPEAK+	8	GND
9	KEY	10	RST_SW
11	SPEAK-	12	GND

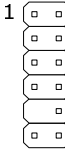

### Power Switch (PW\_BN)

Connect to a 2-pin power button switch. Pressing this button will turn the system power on or off.

### Reset Switch (RST\_SW)

The reset switch is used to reboot the system rather than turning the power ON/OFF. Avoid rebooting the system, if the HDD is still working. Connect the reset switch from the system case to this pin.

### Power LED (PWR\_LED)

The LED will light when the system is on. If the system is in S1 (POS - Power On Suspend) or S3 (STR - Suspend To RAM) state, the LED will blink.

### HDD LED (HD\_LED)

HDD LED shows the activity of a hard disk drive. Avoid turning the power off when the HDD LED still has a lit. Connect the HDD LED from the system case to this pin.

### Speaker (SPEAK)

The speaker from the system case is connected to this pin.

### Audio Connector: AUDIO

This is an interface for connections to external audio devices.

Pin	Signal	Pin	Signal
1	SPDIF_OUT	2	+5V
3	GND	4	KEY
5	LINEOUT_R	6	LINEOUT_L
7	LINEIN_R	8	LINEIN_L
9	MICIN1_R	10	MICIN1_L
11	KEY	12	NC
13	AGND	14	AGND

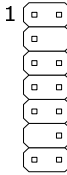

### KBMS Connector: KB/MS

The mainboard provides a PS2 pin header to attach a PS2 keyboard and mouse.

Pin	Signal	Pin	Signal
1	VCCE	2	VCCE
3	NC	4	KEY
5	GND	6	GND
7	KB_DT	8	MS_DT
9	KB_CK	10	MS_CK

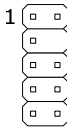

### Serial Port Connectors: COM1 / COM2

COM1/2 pin headers can be used to attach additional ports for serial mouse or other serial devices.

Pin	Signal	Pin	Signal
1	DCD	2	RXD
3	TXD	4	DTR
5	GND	6	DSR
7	RTS	8	CTS
9	RI	10	Key

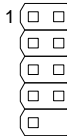

### LVDS Panel Connector: PANEL

The LVDS Panel connector allow you to connect the panel's LVDS cable directly to support 2 single-channel LVDS panels or 1 dual-channel LVDS panel (optional) without any need of a daughter card.

Pin	Signal	Pin	Signal
1	PVDD2	2	PVDD1
3	PVDD2	4	PVDD1
5	PVDD2	6	PVDD1
7	GND	8	GND
9	-LD2C4	10	-LD1C0
11	+LD2C4	12	+LD1C0
13	GND	14	GND
15	-LD2C5	16	-LD1C1
17	+LD2C5	18	+LD1C1
19	GND	20	GND
21	-LD2C6	22	-LD1C2
23	+LD2C6	24	+LD1C2
25	GND	26	GND
27	-LCLK2	28	-LCLK1
29	+LCLK2	30	+LCLK1
31	GND	32	GND
33	-LD2C7	34	-LD1C3
35	+LD2C7	36	+LD1C3
37	SPCLK1	38	GPIOA_CLK
39	SPD1	40	GPIOB_DATA

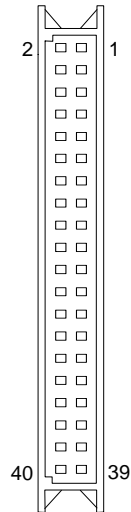

**Note:**

When connecting two single-channel panels, the two panels must have the same timing specification and resolution.

### Inverter Connectors: INVERTER1 / INVERTER2

The mainboard provides 2 inverters for supplying power to the backlight of the LCD panel.

Pin	Signal
1	IVDD
2	IVDD
3	BLON
4	NC
5	BLON
6	BR_CNTR
7	GND
8	GND

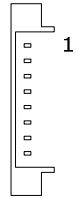

### LPC Connector: LPC

This pin connector is for LPC devices as well as panel power select jumper.

Pin	Signal
1	PVDD1_PWR
3	PVDD1_PWR
5	PVDD2_PWR
7	PVDD2_PWR
9	LPC_AD1
11	-PCI_RST1
13	LPC_AD0
15	LPC_AD2
17	SERIRQ
19	-LPC_DRQ0
21	+5V
23	+5V
25	GND
27	GND

Pin	Signal
2	+3.3V
4	+5V
6	+3.3V
8	+5V
10	SIO_33_CLK
12	GND
14	SIO_48_CLK
16	-LPC_FRAME
18	LPC_AD3
20	-EXTSMI
22	+3.3V
24	+3.3V
26	GND
28	Key

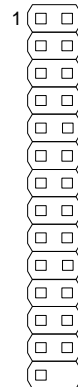

**System Management Bus Connector: SMBus**

This pin header allows you to connect SMBus (System Management Bus) devices. Devices communicate with a SMBus host and/or other SMBus devices using the SMBus interface.

<b>Pin</b>	<b>Signal</b>
1	SMBCK
2	SMBDT
3	GND

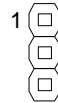

## JUMPERS

The mainboard provides jumpers for setting some mainboard functions. This section will explain how to change the settings of the mainboard functions using the jumpers.

### Clear CMOS: CLEAR\_CMOS

The onboard CMOS RAM stores system configuration data and has an onboard battery power supply. To reset the CMOS settings, set the jumper on pins 2 and 3 while the system is off. Return the jumper to pins 1 and 2 afterwards. Setting the jumper while the system is on will damage the mainboard.

Setting	1	2	3
Normal Operation	ON	ON	OFF
Clear CMOS setting	OFF	ON	ON

Normal:   
1 2 3

Clear:   
1 2 3



#### Caution:

Except when clearing the RTC RAM, never remove the cap on CLEAR\_CMOS1 jumper default position. Removing the cap will cause system boot failure. Avoid clearing the CMOS while the system is on; it will damage the mainboard.

### CF Mode Selector: J1

J1 is the working mode selector for CF Type I connector.

Short = Master; Open = Slave



### Inverter Selector: IVDD\_SEL

IVDD is the VCC selector jumper to determine the input voltage of the panel inverter for panel's back-light.

Setting	1	2	3	4	5	6
+5V	ON	ON	ON	ON	OFF	OFF
+12V	OFF	OFF	ON	ON	ON	ON

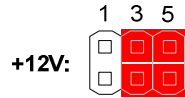
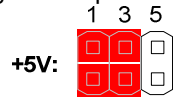

### Panel Power Selector: LPC

The LPC connector contains the VCC selector jumper to determine the panel's signal voltage.

Setting	1	2	3	4	5	6	7	8
+3.3V	ON	ON	OFF	OFF	ON	ON	OFF	OFF
+5V	OFF	OFF	ON	ON	OFF	OFF	ON	ON

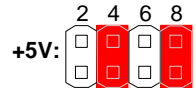
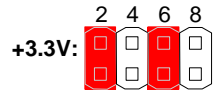

### COM1 Power Selector: J2

J2 is a VCC selector jumper to determine the input voltage for COM1 connector.

Setting	1	2	3
+5V	ON	ON	OFF
+12V	OFF	ON	ON

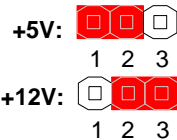

## SLOTS

### Mini Peripheral Component Interconnect: MINIPCI

The miniPCI slot allows you to insert a miniPCI expansion card. First unplug the power supply before adding or removing expansion cards. Read the documentation for the expansion card to see if any changes to the system are necessary.

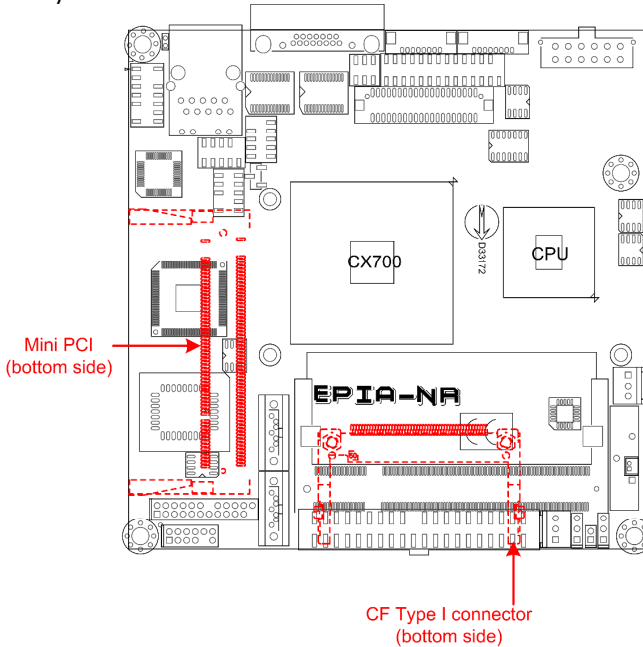

### PCI Interrupt Request Routing

The IRQ (interrupt request line) are hardware lines over which devices can send interrupt signals to the microprocessor. The "PCI & LAN" IRQ pins are typically connected to the PCI bus INT A# ~ INT D# pins as follows:

	Order 1	Order 2	Order 3	Order 4
miniPCI Slot	INT B#	INT C#	INT D#	INT A#

### Compact Flash Type I Connector: CF1

This CF1 connector allows you to connect to a passive 50-pin Type I adapter.

# CHAPTER 3

## BIOS Setup

This chapter gives a detailed explanation of the BIOS setup functions.

## **ENTERING SETUP**

---

Power on the computer and press <Delete> during the beginning of the boot sequence to enter the BIOS setup menu. If you missed the BIOS setup entry point, you may restart the system and try again.

---

## CONTROL KEYS

---

<b>Keys</b>	<b>Description</b>
Up Arrow	Move to the previous item
Down Arrow	Move to the next item
Left Arrow	Move to the item in the left side
Right Arrow	Move to the item in the right side
Enter	Select the item
Escape	Jumps to the Exit menu or returns to the main menu from a submenu
Page Up / +	Increase the numeric value or make changes
Page Down / -	Decrease the numeric value or make changes
F1	General help, only for Status Page Setup Menu and Option Page Setup Menu
F5	Restore the previous CMOS value from CMOS, only for Option Page Setup Menu
F6	Load the default CMOS value from Fail-Safe default table, only for Option Page Setup Menu
F7	Load Optimized defaults
F9	Jumps to the Main Menu
F10	Save all the CMOS changes and exit

## NAVIGATING THE BIOS MENUS

The main menu displays all the BIOS setup categories. Use the Up/Down/Left/Right arrow keys to select any item or sub-menu. Description of the selected/highlighted category is displayed at the bottom of the screen.

An arrow symbol next to a field indicates that a sub-menu is available (see figure below). Press <Enter> to display the sub-menu. To exit the sub-menu, press <Esc>.

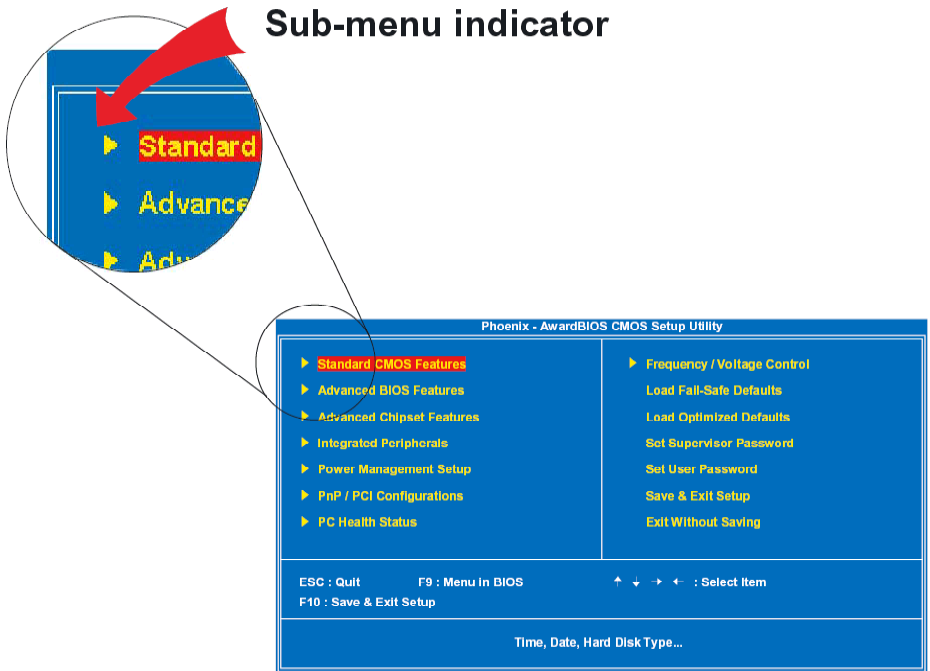

## **GETTING HELP**

---

The BIOS setup program provides a "General Help" screen. You can display this screen from any menu/sub-menu by pressing <F1>. The help screen displays the keys for using and navigating the BIOS setup. Press <Esc> to exit the help screen.

## MAIN MENU

---



### Standard CMOS Features

Use this menu to set basic system configurations.

### Advanced BIOS Features

Use this menu to set the advanced features available on your system.

### Advanced Chipset Features

Use this menu to set chipset specific features and optimize system performance.

### Integrated Peripherals

Use this menu to set onboard peripherals features.

### Power Management Setup

Use this menu to set onboard power management functions.

### PnP/PCI Configurations

Use this menu to set the PnP and PCI configurations.

### PC Health Status

This menu shows the PC health status.

**Frequency/Voltage Control**

Use this menu to set the system frequency and voltage control.

**Load Fail-Safe Defaults**

Use this menu option to load the BIOS default settings for minimal and stable system operations.

**Load Optimized Defaults**

Use this menu option to load BIOS default settings for optimal and high performance system operations.

**Set Supervisor Password**

Use this menu option to set the BIOS supervisor password.

**Set User Password**

Use this menu option to set the BIOS user password.

**Save & Exit Setup**

Save BIOS setting changes and exit setup.

**Exit Without Saving**

Discard all BIOS setting changes and exit setup.

## STANDARD CMOS FEATURES

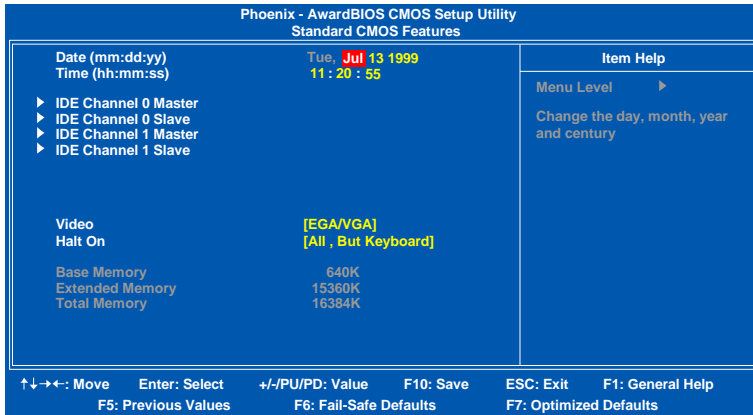

### Date

The date format is [Day, Month Date Year]

### Time

The time format is [Hour : Minute : Second]

### Video

Settings: [EGA/VGA, CGA 40, CGA 80, MONO]

### Halt On

Sets the system's response to specific boot errors. Below is a table that details the possible settings.

Setting	Description
All Errors	System halts when any error is detected
No Errors	System does not halt for any error
All, But Keyboard	System halts for all non-key errors

## IDE DRIVES

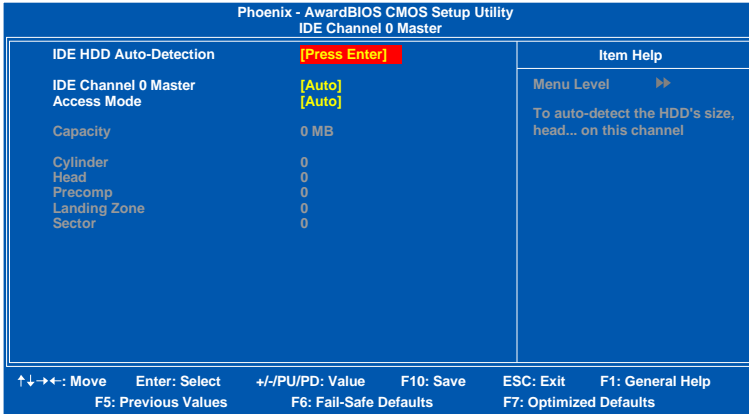

The specifications of your drive must match with the drive table. The hard disk will not work properly if you enter incorrect information in this category. Select "Auto" whenever possible. If you select "Manual", make sure the information is from your hard disk vendor or system manufacturer. Below is a table that details required hard drive information when using the "Manual" mode.

Setting	Description
IDE Channel	The name of this match the name of the menu. Settings: [None, Auto, Manual]
Access Mode	Settings: [CHS, LBA, Large, Auto]
Capacity	Formatted size of the storage device
Cylinder	Number of cylinders
Head	Number of heads
Precomp	Write precompensation
Landing Zone	Cylinder location of the landing zone
Sector	Number of sectors

## ADVANCED BIOS FEATURES

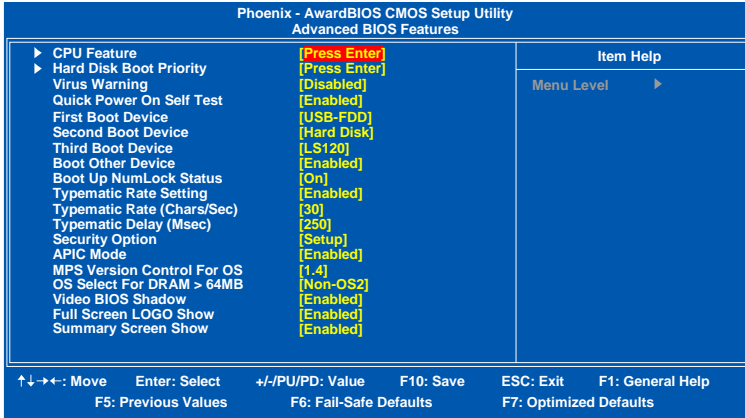

### Virus Warning

Setting	Description
Enabled	Turns on hard disk boot sector virus protection
Disabled	Turns off hard disk boot sector virus protection

### Quick Power On Self-Test

Shortens Power On Self-Test (POST) cycle to enable shorter boot up time.

Setting	Description
Enabled	Shorten Power On Self Test (POST) cycle and bootup time
Disabled	Standard Power On Self Test (POST)

### First/Second/Third Boot Device

Set the boot device sequence as BIOS attempts to load the disk operating system.

Setting	Description
LS120	Boot from LS-120 drive
Hard Disk	Boot from the HDD
CD-ROM	Boot from CD-ROM
ZIP100	Boot from ATAPI ZIP drive
USB-FDD	Boot from USB floppy drive
USB-ZIP	Boot from USB ZIP drive
USB-CDROM	Boot from USB CDROM
Legacy LAN	Boot from network drive
Disabled	Disable the boot device sequence

### Boot Other Device

Enables the system to boot from alternate devices if the system fails to boot from the "First/Second/Third Boot Device" list.

Setting	Description
Enabled	Enable alternate boot device
Disabled	No alternate boot device allowed

### Boot Up NumLock Status

Set the NumLock status when the system is powered on.

Setting	Description
On	Forces keypad to behave as 10-key
Off	Forces keypad to behave as arrow keys

### Typematic Rate Setting

Enables "Typematic Rate" and "Typematic Delay" functions.

Settings: [Enabled, Disabled]

### Typematic Rate (Chars/Sec)

This item sets the rate (characters/second) at which the system retrieves a signal from a depressed key.

Settings: [6, 8, 10, 12, 15, 20, 24, 30]

### **Typematic Delay (Msec)**

This item sets the delay between when the key was first pressed and when the system begins to repeat the signal from the depressed key.

Settings: [250, 500, 750, 1000]

### **Security Option**

Selects whether the password is required every time the System boots, or only when you enter Setup.

<b>Setting</b>	<b>Description</b>
Setup	Password prompt appears only when end users try to run BIOS Setup
System	Password prompt appears every time when the computer is powered on and when end users try to run BIOS Setup

### **APIC Mode**

Enables APIC (Advanced Programmable Interrupt Controller) functionality.

Settings: [Enabled, Disabled]

### **MPS Variation Control for OS**

Settings: [1.1, 1.4]

### **OS Select for DRAM > 64MB**

Select OS2 only if you are running OS/2 operating system with greater than 64MB of RAM on the system.

Settings: [Non-OS2, OS2]

### **Video BIOS Shadow**

Enabled copies Video BIOS to shadow RAM Improves performance.

Settings: [Enabled, Disabled]

### **Full Screen Logo Show**

Show full screen logo during BIOS boot up process.

Settings: [Enabled, Disabled]

**Summary Screen Show**

Show summary screen.

Settings: [Enabled, Disabled]

## CPU FEATURE

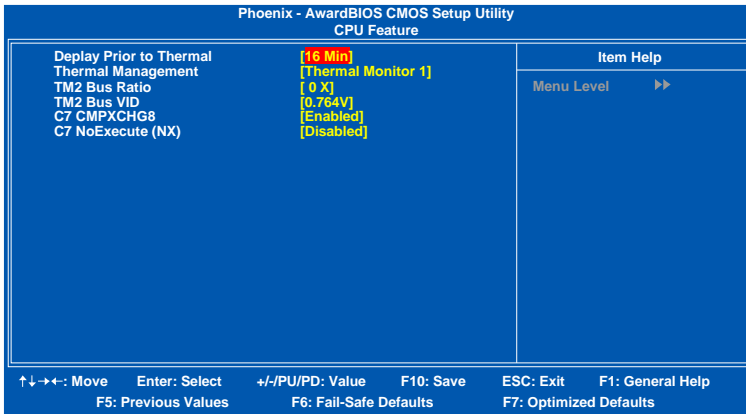

### Deploy Prior to Thermal

Settings: [4 Min, 8 Min, 16 Min, 32 Min]

### Thermal Management

This item sets CPU's thermal control rule to protect CPU from overheat.

Setting	Description
Thermal Monitor 1	On-die throttling
Thermal Monitor 2	Ratio & VID transition

### TM2 Bus Ratio

This item sets the frequency (bus ratio) of the throttled performance that will be initiated when the on die sensor goes from not hot to hot.

Key in a DEC number.

Settings: [Min = 0, Max = 255]

**TM2 Bus VID**

This item sets the voltage of the throttled performance that will be initiated when the on die sensor goes from not hot to hot.

Settings: [0.700V, 0.716V, 0.732V, 0.748V, 0.764V, 0.780V, 0.796V, 0.812V, 0.828V, 0.844V, 0.860V, 0.876V, 0.892V, 0.908V, 0.924V, 0.940V, 0.956V, 0.972V, 0.988V, 1.004V, 1.020V, 1.036V, 1.052V, 1.068V, 1.084V, 1.100V, 1.116V, 1.132V, 1.148V, 1.164V, 1.180V, 1.196V, 1.212V, 1.228V, 1.244V, 1.260V, 1.276V, 1.292V, 1.308V, 1.324V, 1.340V, 1.356V, 1.372V, 1.388V, 1.404V, 1.420V, 1.436V, 1.452V, 1.468V, 1.484V, 1.500V, 1.516V, 1.532V, 1.548V, 1.564V, 1.580V, 1.596V, 1.612V, 1.628V, 1.644V, 1.660V, 1.676V, 1.692V, 1.708]

**C7 CMPXCHG8**

Settings: [Enabled, Disabled]

**C7 NoExecute (NX)**

Settings: [Enabled, Disabled]

## HARD DISK BOOT PRIORITY

---

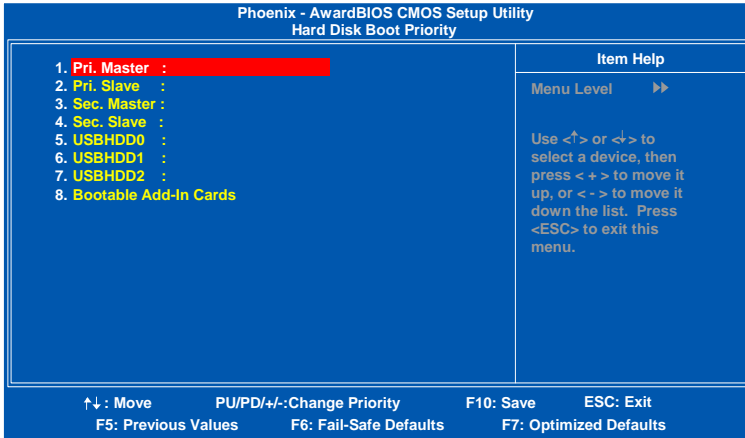

This is for setting the priority of the hard disk boot order when the "Hard Disk" option is selected in the "[First/Second/Third] Boot Device" menu item.

## ADVANCED CHIPSET FEATURES

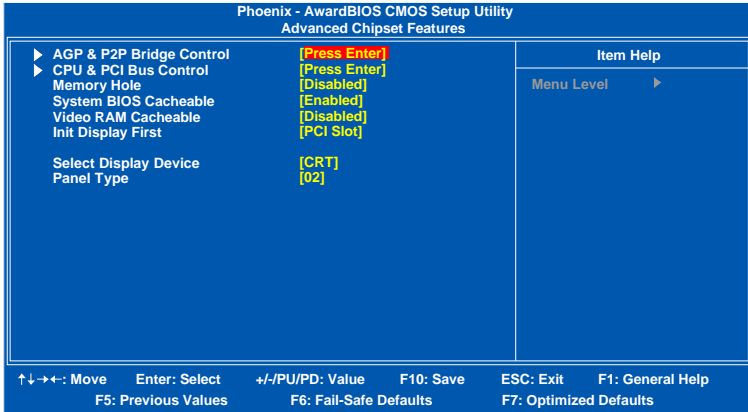

### Caution:

The Advanced Chipset Features menu is used for optimizing the chipset functions. Do not change these settings unless you are familiar with the chipset.

### Memory Hole

Settings: [Disabled, 15M – 16M]

### System BIOS Cacheable

Settings: [Disabled, Enabled]

### Video RAM Cacheable

Settings: [Disabled, Enabled]

### Init Display First

Settings: [PCI Slot, AGP]

### **Select Display Device**

This setting refers to the type of display being used with the system.

Settings: [CRT, LCD, CRT+LCD]

### **Panel Type**

This setting refers to the native resolution of the display being used with the system.

Key in a HEX number.

Settings: [Min = 0000, Max = 000F]

## AGP & P2P BRIDGE CONTROL

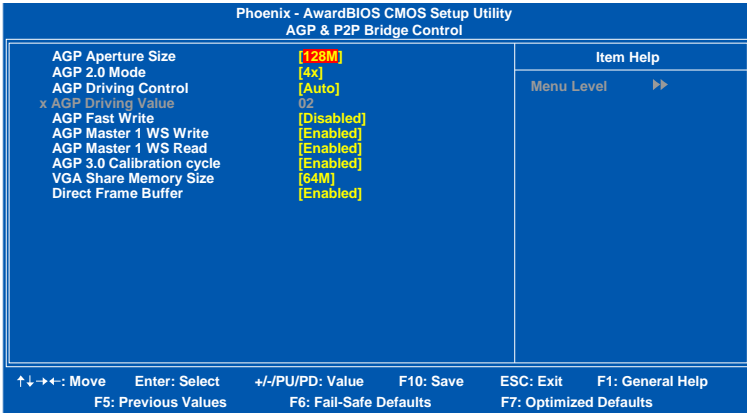

### AGP Aperture Size

This setting controls how much memory space can be allocated to AGP for video purposes. The aperture is a portion of the PCI memory address range dedicated to graphics memory address space. Host cycles that hit the aperture range are forwarded to the AGP without any translation.

Settings: [32MB, 64MB, 128MB, 256MB, 512MB, 1G]

### AGP 2.0 Mode

This mainboard supports the AGP 4x interface. When the AGP 4x video card is used, it can transfer video data at 1066MB/s. AGP 4x is backward compatible, leave the default 4x mode on. AGP 4x mode can be detected automatically once you plug in the AGP 4x card.

Settings: [4x, 2x, 1x]

### **AGP Driving Control**

This item is used to signal driving current on AGP cards to auto or manual.

Settings: [Auto, Manual]

### **AGP Fast Write**

This item is used to enable or disable the caching of display data for the video memory of the processor.

Settings: [Enabled, Disabled]

### **AGP Master 1 WS Write**

Settings: [Enabled, Disabled]

### **AGP Master 1 WS Read**

Settings: [Enabled, Disabled]

### **AGP 3.0 Calibration Cycle**

Settings: [Enabled, Disabled]

### **VGA Share Memory Size**

Settings: [Disabled, 32M, 64M, 128M]

### **Direct Frame Buffer**

Settings: [Enabled, Disabled]

## CPU & PCI BUS CONTROL

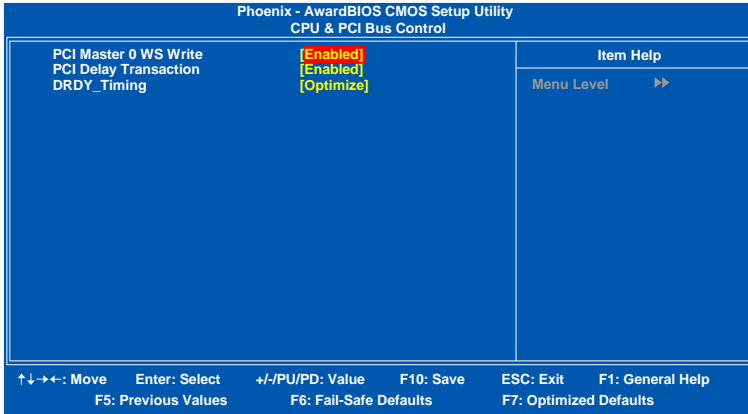

### PCI Master 0 WS Write

Settings: [Enabled, Disabled]

### PCI Delay Transaction

Settings: [Enabled, Disabled]

### DRDY\_Timing

Settings: [Slowest, Default, Optimize]

## INTEGRATED PERIPHERALS

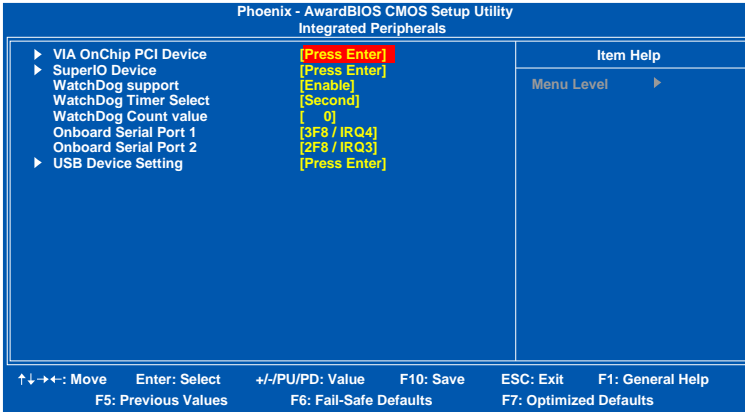

### WatchDog support

Settings: [Enabled, Disabled]

### WatchDog Timer Select

Settings: [Minute, Second]

### WatchDog Count Value

Key in a DEC number.

Settings: [Min = 0, Max = 255]

### Onboard Serial Port 1

Settings: [Disabled, 3F8 / IRQ4, 2F8 / IRQ3, 3E8 / IRQ4, 2E8 / IRQ3, Auto]

### Onboard Serial Port 2

Settings: [Disabled, 3F8 / IRQ4, 2F8 / IRQ3, 3E8 / IRQ4, 2E8 / IRQ3, Auto]

## VIA ONCHIP PCI DEVICE

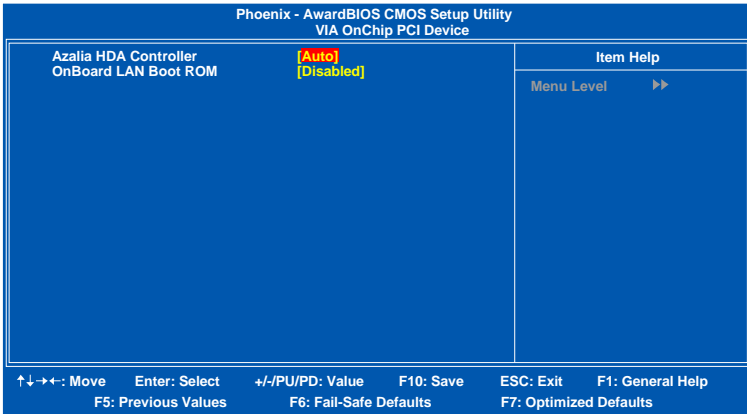

### Azalia HAD Controller

Settings: [Auto, Disabled]

### OnBoard LAN Boot ROM

Settings: [Enabled, Disabled]

## USB DEVICE SETTING

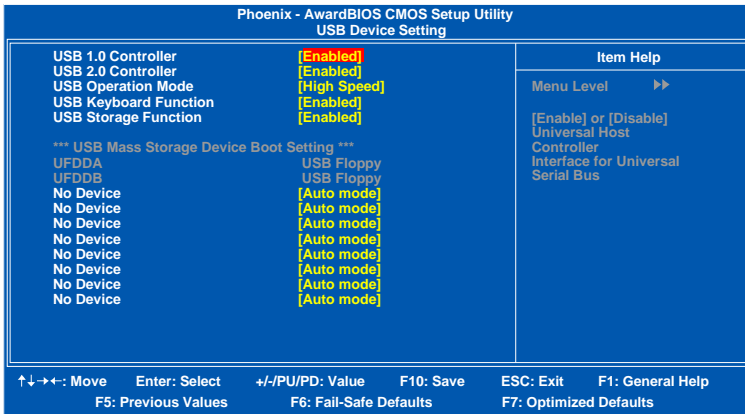

### USB 1.0 Controller

Enable or disable Universal Host Controller Interface for Universal Serial Bus.

Settings: [Enabled, Disabled]

### USB 2.0 Controller

Enable or disable Enhanced Host Controller Interface for Universal Serial Bus.

Settings: [Enabled, Disabled]

### USB Operation Mode

Auto decide USB device operation mode.

Setting	Description
High Speed	If USB device was high speed device, then it operated on high speed mode. If USB device was full/low speed device, then it operated on full/low speed mode.
Full/Low Speed	All of USB Device operated on full/low speed mode

**USB Keyboard Function**

Enable or disable Legacy support of USB Keyboard

Settings: [Enabled, Disabled]

**USB Storage Function**

Enable or disable Legacy support of USB Mass Storage

Settings: [Enabled, Disabled]

**No Device**

<b>Setting</b>	<b>Description</b>
Auto mode	According to contents of USB MSD decide boot up type.
FDD mode	The USB MSD always boot up as floppy disk.
HDD mode	The USB MSD always boot up as hard disc.

## POWER MANAGEMENT SETUP

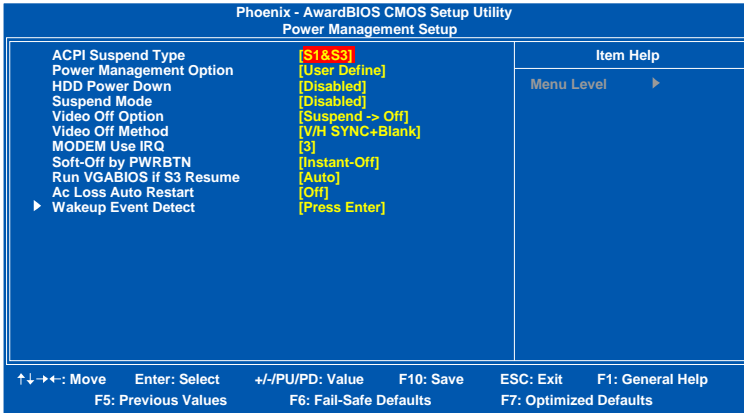

### ACPI Suspend Type

Setting	Description
S1(POS)	S1/Power On Suspend (POS) is a low power state. In this state, no system context (CPU or chipset) is lost and hardware maintains all system contexts.
S3(STR)	S3/Suspend To RAM (STR) is a power-down state. In this state, power is supplied only to essential components such as main memory and wakeup-capable devices. The system context is saved to main memory, and context is restored from the memory when a "wakeup" event occurs.
S1 & S3	Depends on the OS to select S1 or S3.

### Power Management Option

Settings: [User Define, Min Saving, Max Saving]

### HDD Power Down

Sets the length of time for a period of inactivity before powering down the hard disk.

Settings: [Disabled, 1~15(minutes)]

### Suspend Mode

Settings: [Disabled, 1 Min, 2 Min, 4 Min, 6 Min, 8 Min, 10 Min, 20 Min, 30 Min, 40 Min, 1 Hour]

### Video Off Option

Select whether or not to turn off the screen when system enters power saving mode, ACPI OS such as Windows XP will override this option.

Setting	Description
Always On	Screen is always on even when system enters power saving mode
Suspend -> Off	Screen is turned off when system enters power saving mode

### Video Off Method

Settings: [Blank Screen, V/H SYNC+Blank, DPMS Support]

### MODEM Use IRQ

Settings: [NA, 3, 4, 5, 7, 9, 10, 11]

### Soft-Off by PWRBTN

Setting	Description
Delay 4 Sec	System is turned off if power button is pressed for more than four seconds
Instant-Off	Power button functions as a normal power-on/-off button

### Run VGABIOS if S3 Resume

Select whether to run VGA BIOS if resuming from S3 state. This is only necessary for older VGA drivers.

Settings: [Auto, Yes, No]

### AC Loss Auto restart

The field defines how the system will respond after an AC power loss during system operation.

Setting	Description
Off	Keeps the system in an off state until the power button is pressed
On	Restarts the system when the power is back
Former-Sts	Former-Sts

## WAKEUP EVENT DETECT

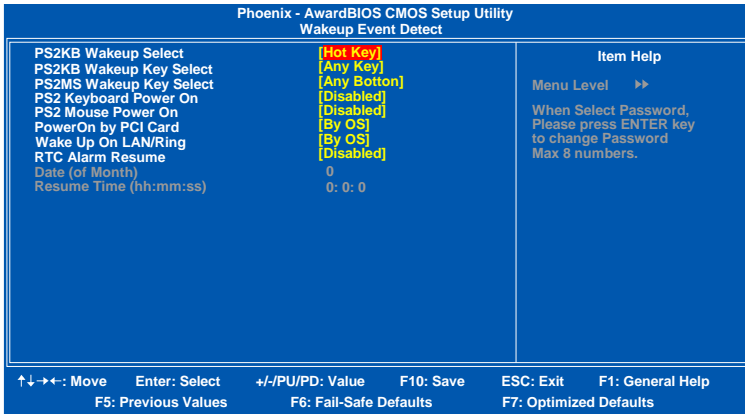

### PS2KB Wakeup Select

When selecting Password, press Enter to change password. The maximum number of characters is eight.

Settings: [Hot Key, Password]

### PS2KB Wakeup Key Select

Sets a Hot Key to restore the system from the power saving mode to an active state.

Settings: [Ctrl+F1, Ctrl+F2, Ctrl+F3, Ctrl+F4, Ctrl+F5, Ctrl+F6, Ctrl+F7, Ctrl+F8, Ctrl+F9, Ctrl+F10, Ctrl+F11, Ctrl+F12, Power, Wake, Any Key]

### PS2MS Wakeup Key Select

Enables any mouse activity to restore the system from the power saving mode to an active state.

Settings: [Any Button, Left Button, Right Button]

**PS2 Keyboard Power On**

Settings: [Disabled, Enabled]

**PS2 Mouse Power On**

Settings: [Disabled, Enabled]

**PowerOn by PCI Card**

Enables activity detected from any PCI card to power up the system or resume from a suspended state. Such PCI cards include LAN, onboard USB ports, etc.

Settings: [By OS, Enabled]

**Wake Up On LAN/Ring**

Settings: [By OS, Enabled]

**RTC Alarm Resume**

Sets a scheduled time and/or date to automatically power on the system.

Settings: [Disabled, Enabled]

**Date (of Month)**

The field specifies the date for "RTC Alarm Resume".

**Resume Time (hh:mm:ss)**

The field specifies the time for "RTC Alarm Resume".

## PNP/PCI CONFIGURATIONS

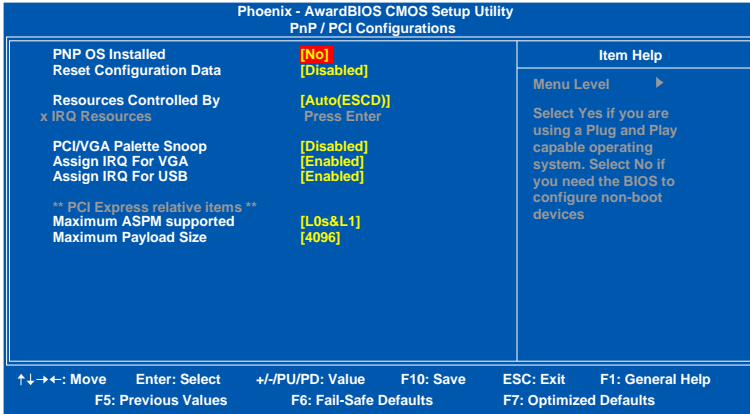

**Note:**

This section covers some very technical items and it is strongly recommended to leave the default settings as is unless you are an experienced user.

### PNP OS Installed

Setting	Description
Yes	BIOS will only initialize the PnP cards used for booting (VGA, IDE, SCSI). The rest of the cards will be initialized by the PnP operating system
No	BIOS will initialize all the PnP cards

### Reset Configuration Data

This field should usually be left "Disabled".

Setting	Description
Enabled	Resets the ESCD (Extended System Configuration Data) after exiting BIOS Setup if a newly installed PCI card or the system configuration prevents the operating system from loading
Disabled	Default setting

**Resource Controlled By**

Enables the BIOS to automatically configure all the Plug-and-Play compatible devices.

<b>Setting</b>	<b>Description</b>
Auto(ESCD)	BIOS will automatically assign IRQ, DMA and memory base address fields
Manual	Unlocks "IRQ Resources" for manual configuration

**PCI/VGA Palette Snoop**

Settings: [Disabled, Enabled]

**Assign IRQ For VGA/USB**

Assign IRQ for VGA and USB devices.

Settings: [Disabled, Enabled]

**Maximum ASPM supported**

Control maximum level of ASPM supported on the given PCI Express links on the system.

Settings: [L0, L0s, L1, L0s&L1]

**Maximum Payload Size**

Set maximum TLP payload size for the PCI Express devices. The unit is byte.

Settings: [128, 256, 512, 1024, 2048, 4096]

## PC HEALTH STATUS

---

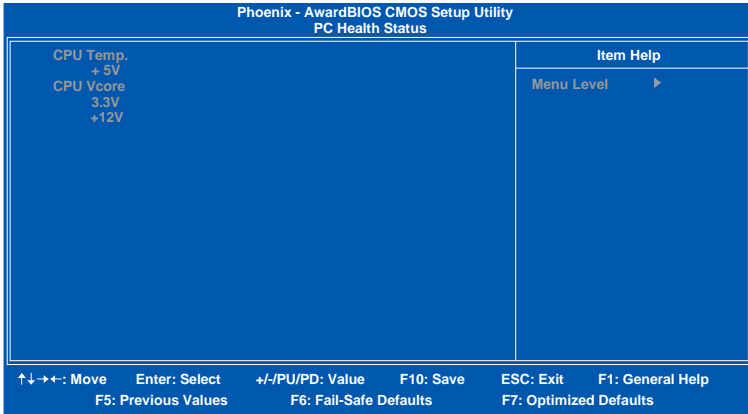

The PC Health Status displays the current status of all of the monitored hardware devices/components such as CPU voltages, temperatures and fan speeds.

## FREQUENCY / VOLTAGE CONTROL

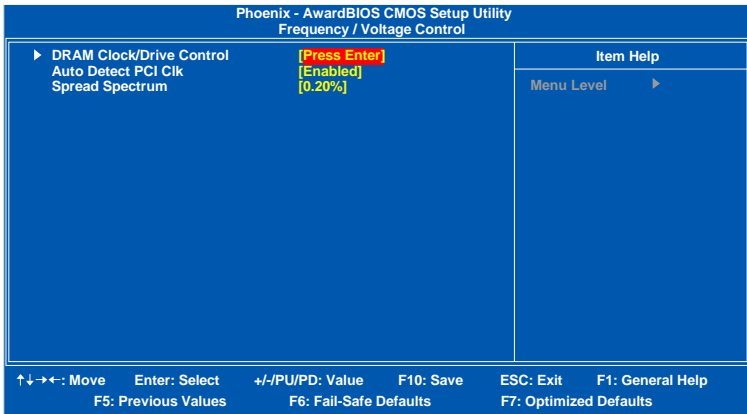

### Auto Detect PCI Clk

Settings: [Disabled, Enabled]

### Spread Spectrum

When the mainboard's clock generator pulses, the extreme values (spikes) of the pulses create EMI (Electromagnetic Interference). The Spread Spectrum function reduces the EMI generated by modulating the pulses so that the spikes of the pulses are reduced to flatter curves.

Settings: [Disabled, 0.20%, 0.25%, 0.35%]

## DRAM CLOCK/DRIVE CONTROL

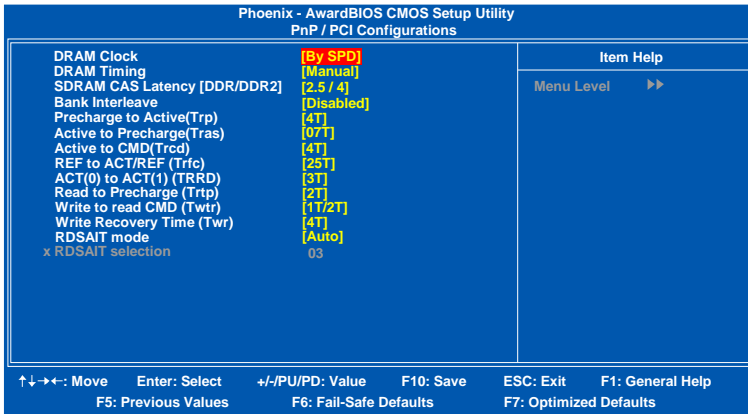

### DRAM Clock

The chipset supports synchronous and asynchronous mode between host clock and DRAM clock frequency.

Settings: [By SPD, 100 MHz, 133 MHz, 166 MHz, 200MHz, 266MHz, 333MHz]

### DRAM Timing

The value in this field depends on the memory modules installed in your system. Changing the value from the factory setting is not recommended unless you install new memory that has a different performance rating than the original modules.

Settings: [Manual, Auto By SPD]

### SDRAM CAS Latency [DDR/DDR2]

Settings: [1.5/2, 2/3, 2.5/4, 3/5]

### Bank Interleave

Settings: [Disabled, 2 Bank, 4 Bank, 8 Bank]

### Precharge to Active (Trp)

Settings: [2T, 3T, 4T, 5T]

**Active to Precharge (Tras)**

Settings: [05T ~ 20T]

**Active to CMD (Trcd)**

Settings: [2T, 3T, 4T, 5T]

**REF to ACT/REF (Trfc)**

Settings: [8T ~ 71T]

**ACT(0) to ACT(1) (TRRD)**

Settings: [2T, 3T, 4T, 5T]

**Read to Precharge (Trtp)**

Settings: [2T, 3T]

**Write to Read CMD (Twtr)**

Settings: [1T/2T, 2T/3T]

**Write Recovery Time (Twr)**

Settings: [2T, 3T, 4T, 5T]

**RDSAIT mode**

Settings: [Auto, Manual]

## LOAD FAIL-SAFE DEFAULTS

---

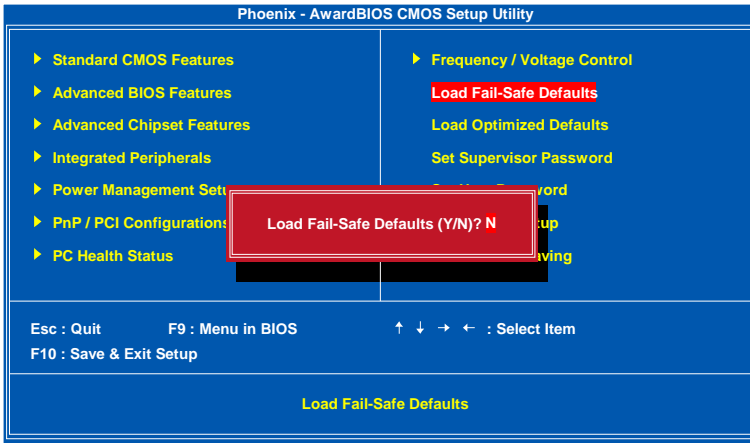

This option is for restoring all the default fail-safe BIOS settings. These values are set by the mainboard manufacturer to provide a stable system with basic performance.

Entering "Y" loads the default fail-safe BIOS values.

---

## LOAD OPTIMIZED DEFAULTS

---

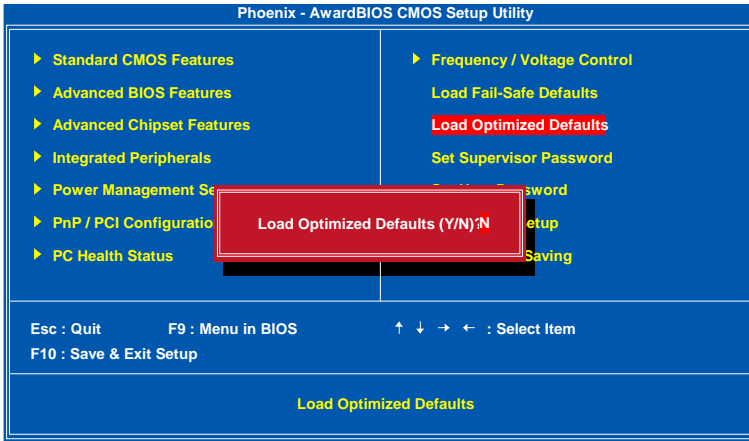

This option is for restoring all the default optimized BIOS settings. The default optimized values are set by the mainboard manufacturer to provide a stable system with optimized performance.

Entering "Y" loads the default optimized BIOS values.

## SET SUPERVISOR / USER PASSWORD

---

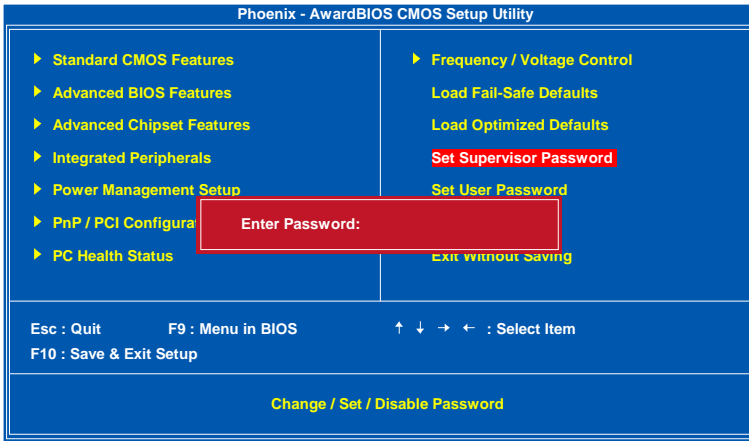

This option is for setting a password for entering BIOS Setup. When a password has been set, a password prompt will be displayed whenever BIOS Setup is run. This prevents an unauthorized person from changing any part of your system configuration.

There are two types of passwords you can set. A supervisor password and a user password. When a supervisor password is used, the BIOS Setup program can be accessed and the BIOS settings can be changed. When a user password is used, the BIOS Setup program can be accessed but the BIOS settings cannot be changed.

To set the password, type the password (up to eight characters in length) and press <Enter>. The password typed now will clear any previously set password from CMOS memory. The new password will need to be reentered to be confirmed. To cancel the process press <Esc>.

To disable the password, press <Enter> when prompted to enter a new password. A message will show up to confirm disabling the password. To cancel the process press <Esc>.

Additionally, when a password is enabled, the BIOS can be set to request the password each time the system is booted. This would prevent unauthorized use of the system. See "Security Option" in the "Advanced BIOS Features" section for more details.

## SAVE & EXIT SETUP

---

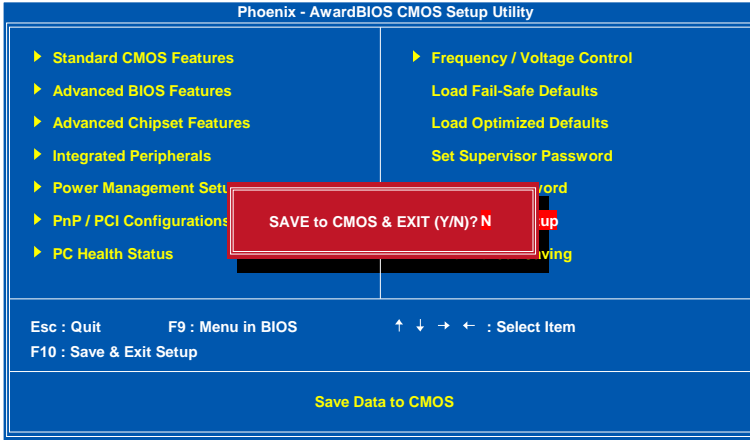

Entering "Y" saves any changes made and exits the program.

Entering "N" will cancel the exit request.

## EXIT WITHOUT SAVING

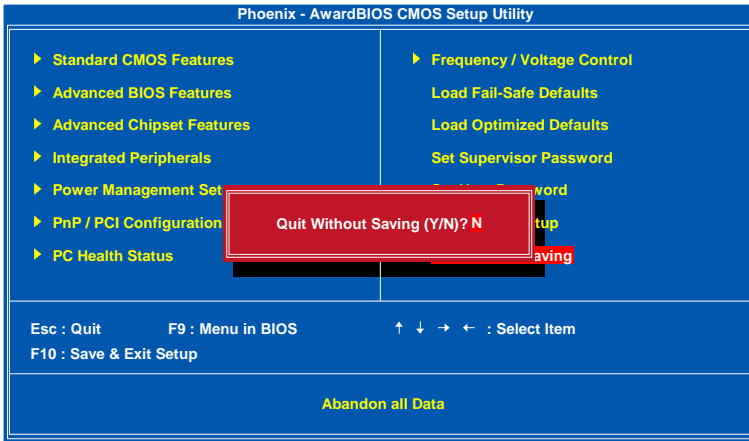

Entering "Y" discards any changes made and exits the program.

Entering "N" will cancel the exit request.



# CHAPTER 4

## Driver Installation

This chapter gives you brief descriptions of each mainboard driver and application. You must install the VIA chipset drivers first before installing other drivers such as audio or VGA drivers. The applications will only function correctly if the necessary drivers are already installed.

## DRIVER UTILITIES

---

### Getting Started

The Driver Utilities CD contains the driver utilities and software for enhancing the performance of the mainboard.



**Note:**

The driver utilities and software are updated from time to time. The latest updated versions are available at <http://www.viaembedded.com/>

## Running the Driver Utilities CD

To start using the CD, insert the CD into the CD-ROM or DVD-ROM drive. The CD should run automatically after closing the CD-ROM or DVD-ROM drive. The driver utilities and software menu screen should then appear on the screen. If the CD does not run automatically, click on the "Start" button and select "Run..." Then type: "D:\Setup.exe".

**Note:**

D: might not be the drive letter of the CD-ROM/DVD-ROM in your system.

## CD CONTENT

---

- ☒ **VIA 4in1 Drivers:** Contains VIA ATAPI Vendor Support Driver (enables the performance enhancing bus mastering functions on ATA-capable Hard Disk Drives and ensures IDE device compatibility), AGP VxD Driver (provides service routines to your VGA driver and interface directly to hardware, providing fast graphical access), IRQ Routing Miniport Driver (sets the system's PCI IRQ routing sequence) and VIA INF Driver (enables the VIA Power Management function).
- ☒ **VIA Graphics Driver:** Enhances the onboard VIA graphic chip.
- ☒ **VIA Audio Driver:** Enhances the onboard VIA audio chip.
- ☒ **VIA USB 2.0 Driver:** Enhances VIA USB 2.0 ports.
- ☒ **VIA LAN Driver:** Enhances the onboard VIA 10/100M LAN chip.
- ☒ **VIA RAID Driver:** Support for SATA RAID devices.



**Note:**

EPIA-NR does not support video outputs of HDTV (YPbPr) and LCD. Please DO NOT enable these functions in this system.